

Instructions

Thank you for choosing GooLoo Mover!

Lift up to
330 lbs
with the Crowbar

Move up to
660 lbs
with 4 Trolleys

Your complete GooLoo Mover set includes:

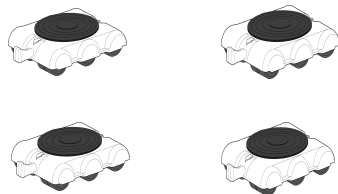

4 Trolleys

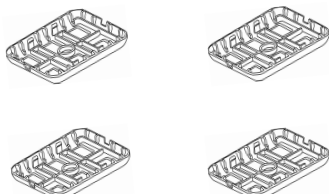

4 Carpet Frames

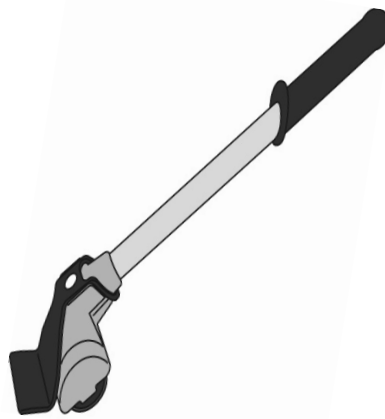

1 Crowbar



3 Short Rings



1 Crowbar Cradle

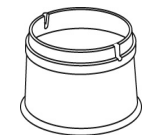

3 Tall Rings

PLEASE READ ALL INSTRUCTIONS BEFORE USE.

Clean the floor before using GooLoo Mover.

Furniture without legs — Max 660 lbs

1. Insert Crowbar completely under corner of furniture.
2. Press down gently on Crowbar handle to lift furniture. (Fig. 1)
3. Hold Trolley by knob and insert under corner of furniture.
4. Point Trolley arrow in the direction of travel. (Fig. 2)
5. Lower furniture slowly by releasing pressure on Crowbar handle.
6. Repeat steps 2-6 for remaining three Trolleys.
7. Push furniture from a low position to roll safely across floor. (Fig. 3)
8. Remove Trolleys after moving furniture to new location.



(Fig.1)

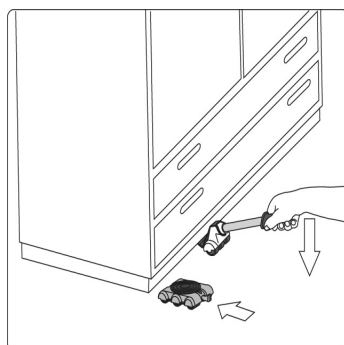

(Fig.2)

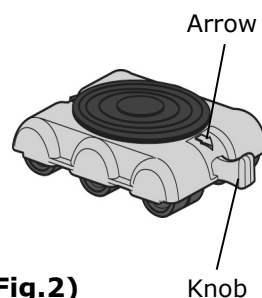

Arrow

Knob

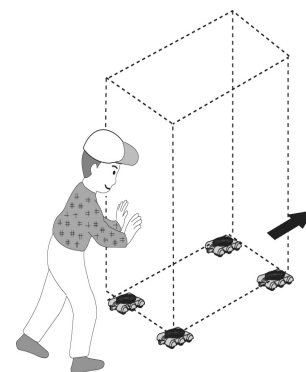

(Fig.3)

Furniture WITH legs — Max 440 lbs

- Choose size and number of Rings to raise Crowbar to height of furniture.
- Combine rings with Cradle on top and snap Crowbar into Cradle. (Fig. 4)
- Position Ring Tower to insert Crowbar correctly under furniture corner. (Fig. 5)
- Follow steps 2-8 above.

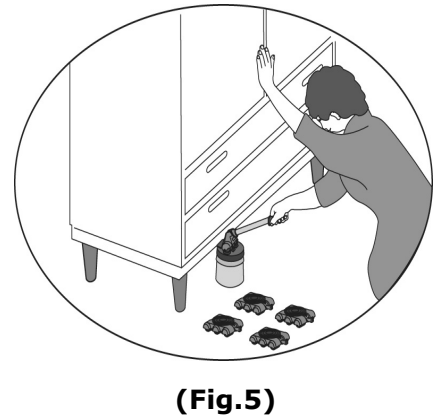
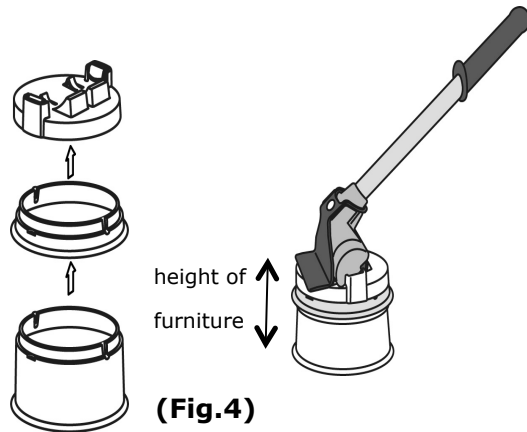

Moving across carpeting

- Snap Frames to undersides of all Trolleys. (Fig. 6)
- Follow steps 1-8 above.
- Remember steps A-D above when moving furniture with legs.

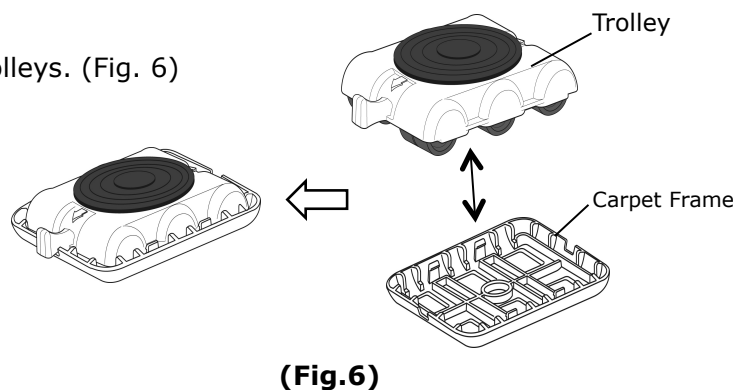

Tips for smarter moving

- If furniture sits flat on floor, push gently against it to make a gap for Crowbar. (Fig. 7)
- When moving furniture less than 220 lbs, use 3 Trolleys: 2 in front, 1 in back. (Fig. 8)
- When adding the last Trolley, use an extra Short Ring to safely position Crowbar under corner.



(Fig.7)

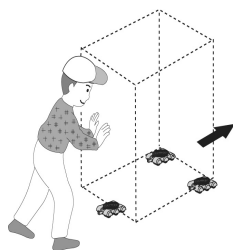

(Fig.8)

CAUTION:

- Use this product only for its intended purpose.
- This product cannot be used to move up and down steps.
- Heating or tampering with this product will damage it.
- When lifting tall furniture, be sure no one is standing nearby.
- Do not lift furniture when hands or feet are underneath it.

GooLoo® (Patent No. 14355822)

GooLoo Tools International Co., LTD